

Tolerances
 1-20=+/-0.2
 20-30=+/-0.3
 30-40=+/-0.4
 40-50=+/-0.5
 50-100=+/-0.75
 100-300=+/-1.5
 Angles=+/-1
Dimensions are in Millimeters

| | | |
|--|------------------|------------------|
| Revisions Description/Approved/Date | Approved M.H. | Date 08/15/02 |
| | Checked M.H. | Date 08/15/02 |
| | Drawn M.D.L. | Date 08/15/02 |
| NOTES (plating thickness in micro-inches): 1. Per QQ-B-626 2. Per QQ-S-764 3. Per QQ-C-530 4. Per QQ-B-750 5. Per MIL-P-19468 6. Per ZZ-R-765 7. Per WW-T-799 8. Gold pl. 5 min. over nickel pl. 50 min. over copper strike 9. Nickel pl. 100 min. over copper strike 10. Per QQ-P-35 11. Gold pl. 30 min. over nickel pl. 50 min. over copper strike | | |

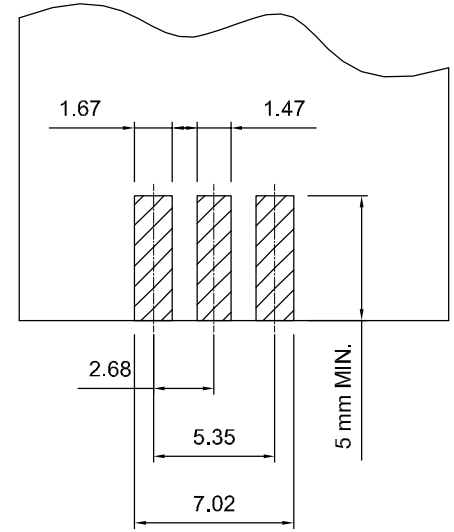
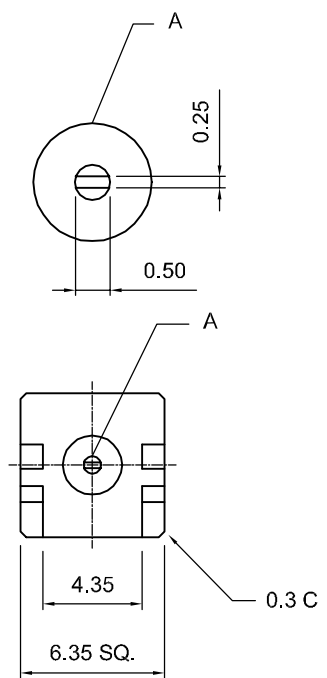
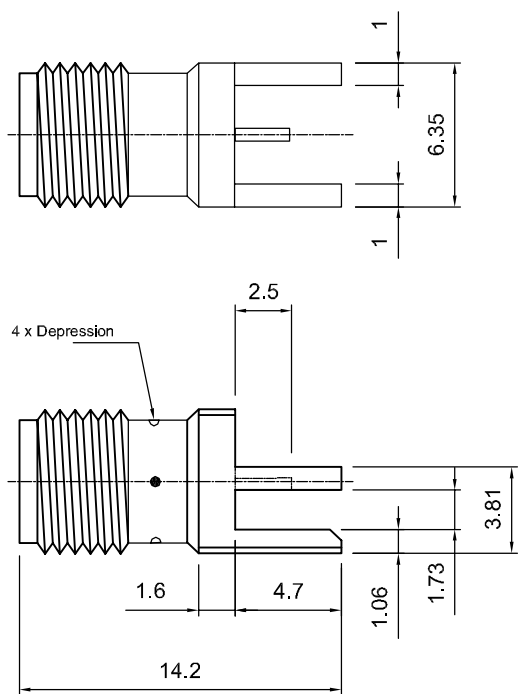

LANDING PAD DIMENSIONS

| ITEM | MATERIAL | FINISH |
|-------------------|----------------|---------------|
| Connector Body | Brass, Note 1 | Gold, Note 8 |
| Center Contact: F | BeCu, Note 3 | Gold, Note 11 |
| Insulation | Teflon, Note 5 | None |
| Ferrule | | |
| Gasket | | |
| Hex Nut | | |
| Lock Washer | | |



Lighthouse Technologies, Inc.
 5640 Kearny Mesa Road, Suite N
 San Diego, California 92111
 Part Number:
LTI-SASF75ZGT

| | | |
|---|------------------------|------------------------|
| Description SMA end launch PCB jack with tab termination for 0.062" pcb. | | |
| Gold plated brass body, Teflon dielectric. | | |
| Scale 1:1 | Drawing No. SASF75Z | File Name SASF75ZGT |